

THIS DOCUMENT AND THE DATA DISCLOSED HEREIN OR WHEREWITH IS NOT TO BE REPRODUCED, USED OR DISCLOSED IN WHOLE OR IN PART TO ANYONE WITHOUT THE PERMISSION OF ESL.

NOTES:

1. COMPLETE ASSEMBLY IS UL LISTED AS A MANUAL TRANSFER SWITCH UNDER UL 1008 (TRANSFER SWITCH STANDARD)
2. STANDARD UNIT IS NON-SWITCHED NEUTRAL. FOR SWITCHED NEUTRAL PLEASE CONSULT FACTORY.
3. FINISH: POWDER COATED SERIES W49
4. OPTIONAL PLUG KITS AVAILABLE
5. TYPE 3R CONSTRUCTION
6. NOT FOR INDOOR USE
7. FOAM SEAL INSIDE OF ALL CONDUIT ENTRIES

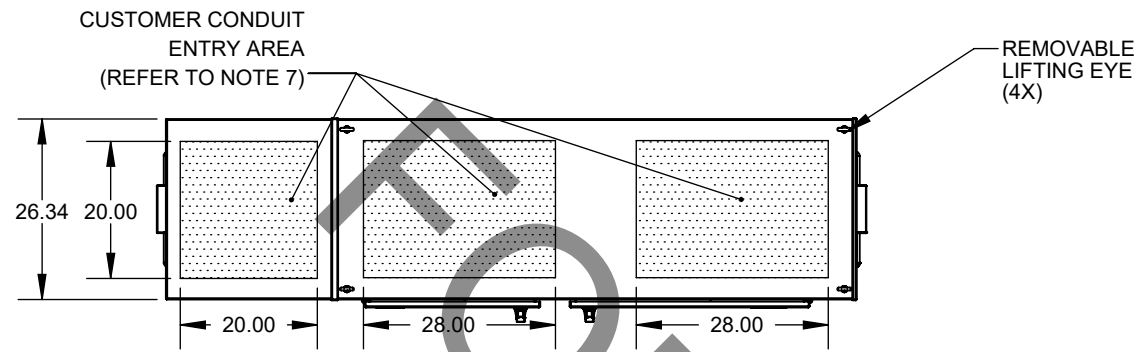
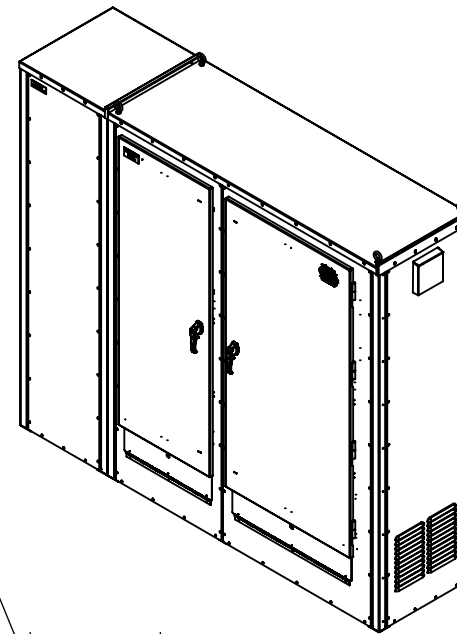

TOP VIEW

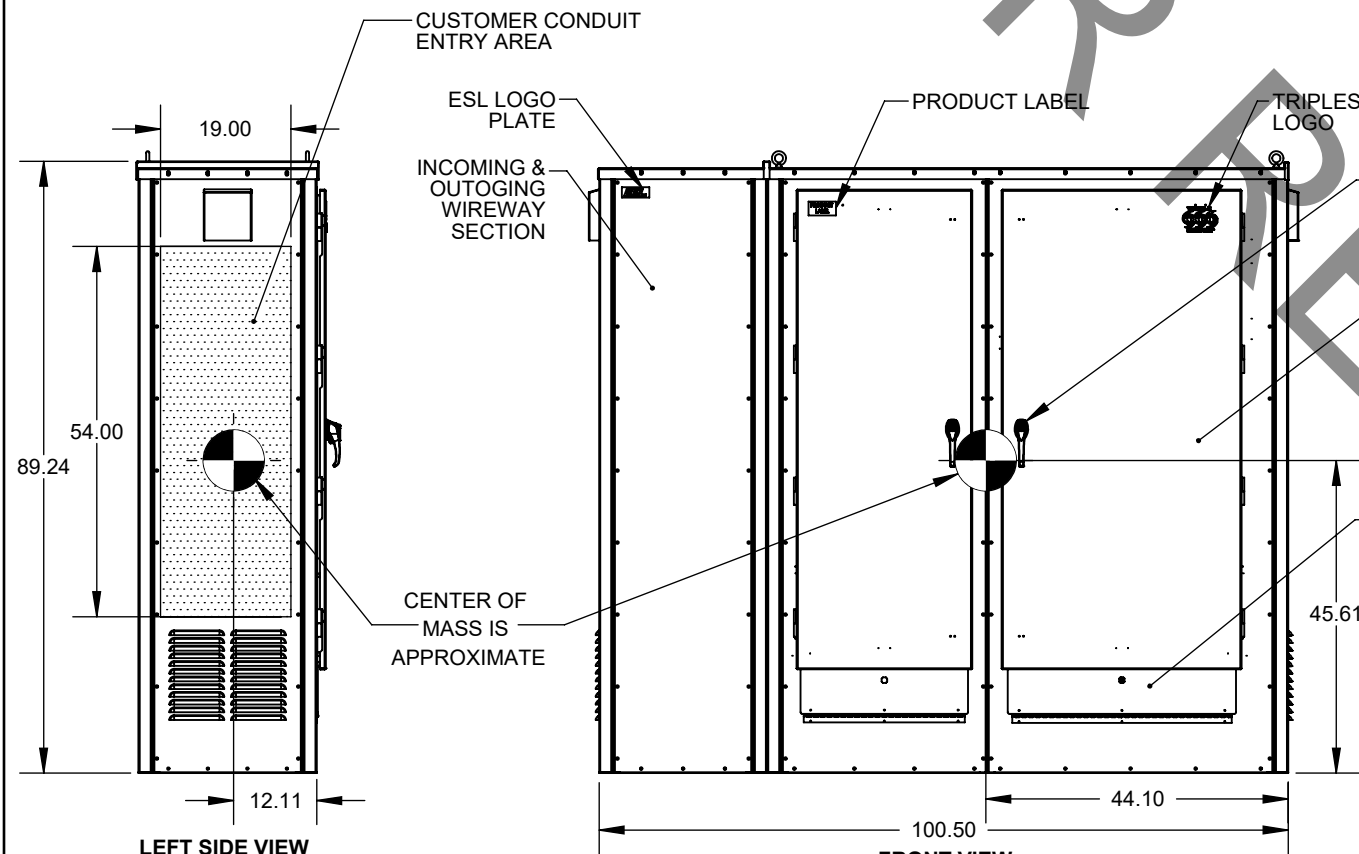

FRONT VIEW

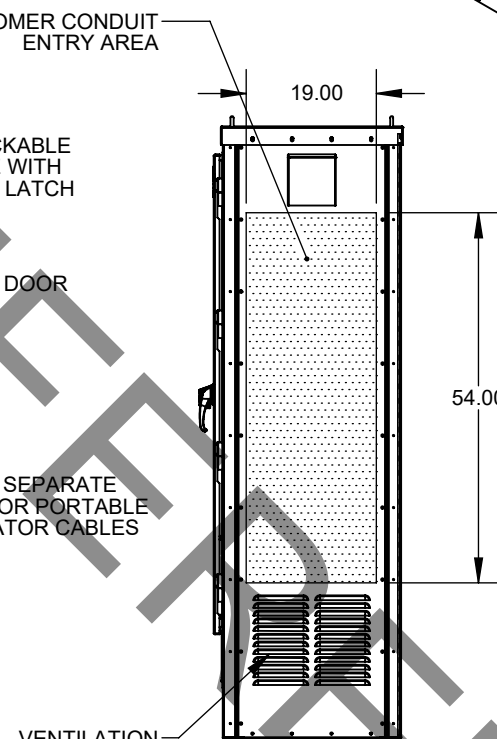

RIGHT SIDE VIEW

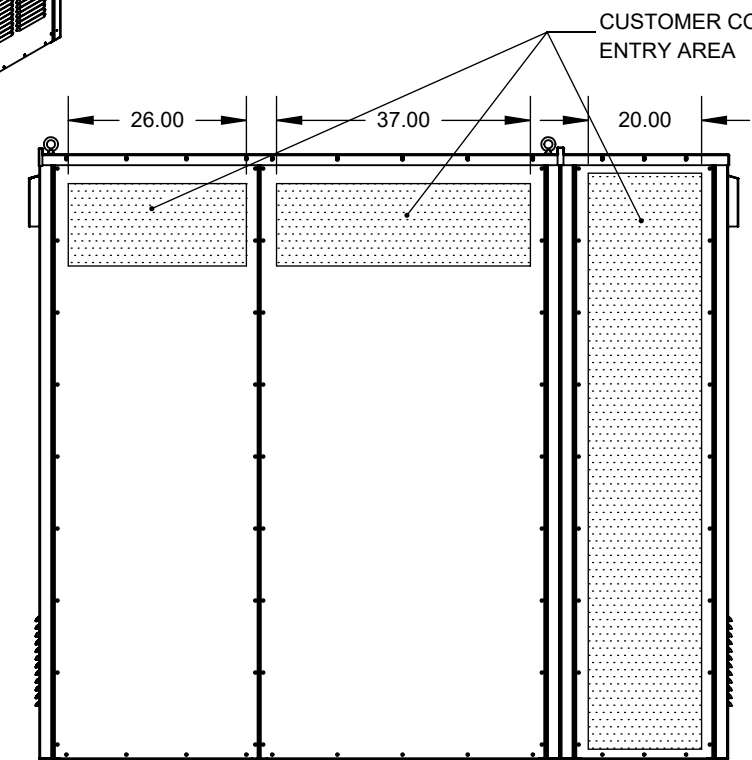

BACK VIEW

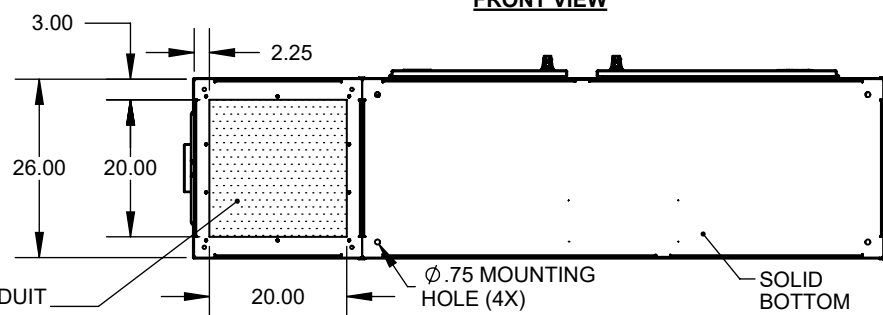

BOTTOM VIEW

TABLE OF KAIC RATINGS

DISCONNECTS SWITCH	SHORT CIRCUIT RATING
SWITCH	10KA
CIRCUIT BREAKER	50KAIC



ESL POWER SYSTEMS

UL 3NLT US LISTED

1601-3000A 50/60Hz 3 ϕ + N + G TRIPLE TRANSFER SWITCH

ITEM #: 3132-SERIES SERIAL # _____ MFG. DATE: _____ TYPE: 3R

SHORT CIRCUIT CURRENT RATING: 50,000 RMS SYMMETRICAL AMPS
 COURANT NOMINAL DE COURT-CIRCUIT: 50,000 RMS SYMMETRIQUES AMPERES
 Corona, CA \leftrightarrow (800)922-4188 \leftrightarrow (951)739-7000 \leftrightarrow info@eslpwr.com

MATERIAL:	GALV STEEL
THICKNESS:	12 GAUGE
COLOR/FINISH:	WRINKLE GRAY (RAL 7035)
REFERENCE:	1050-31T-ASSY

ESL POWER SYSTEMS, INC.
 CORONA, CALIFORNIA
 (951) 739-7000 (800) 922-4188
 eslpwr.com - info@eslpwr.com

EST. WEIGHT: 3300 Lbs.

1601-3000A
 TRIPLE TRANSFER SWITCH
 3 PHASE + N + G

PART NUMBER
3132-SERIES

SHEET
 1 OF 2

MODEL: 3132-SERIES

0	MAQ	11/30/2021
REV.	BY	DATE

FOR REFERENCE
 DESCRIPTION

THIS DOCUMENT AND THE DATA DISCLOSED HEREIN OR WHEREWITH IS NOT TO BE REPRODUCED, USED OR DISCLOSED IN WHOLE OR IN PART TO ANYONE WITHOUT THE PERMISSION OF ESL.

NOTES:

1. CONDUIT HUBS AND MOUNTING HARDWARE TO BE SUPPLIED BY OTHERS.



TOP VIEW

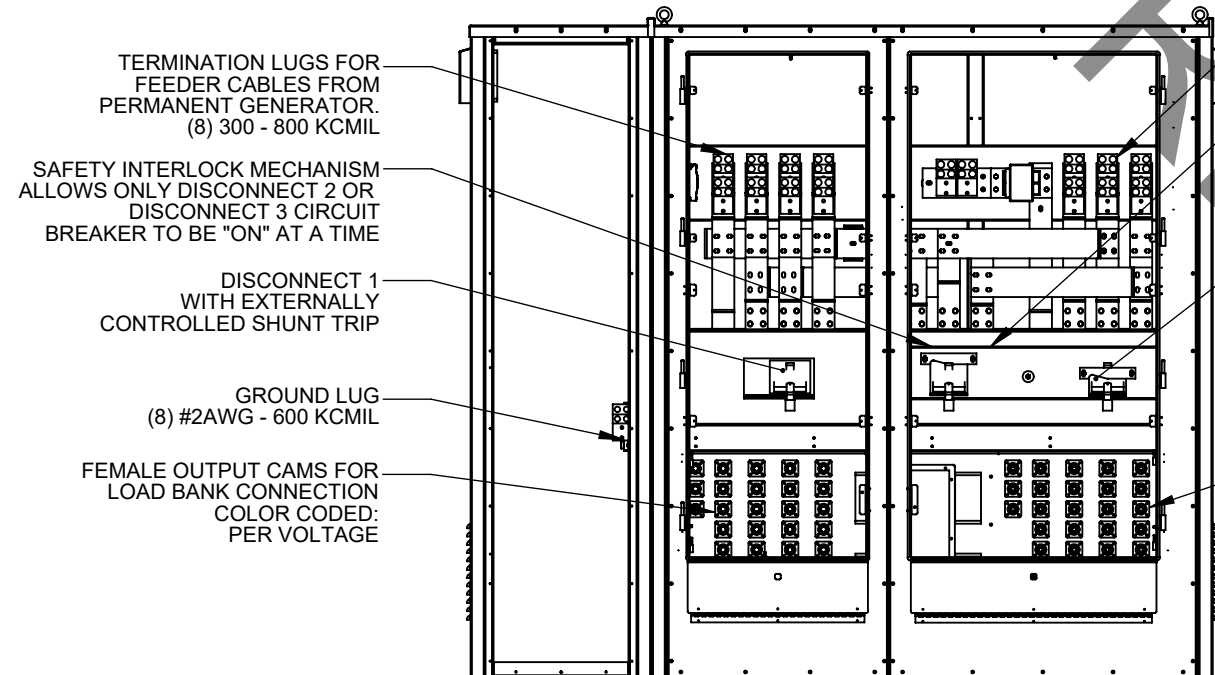

FRONT VIEW
(DOORS AND DEADFRONTS REMOVED)



RIGHT VIEW
(DOORS REMOVED)

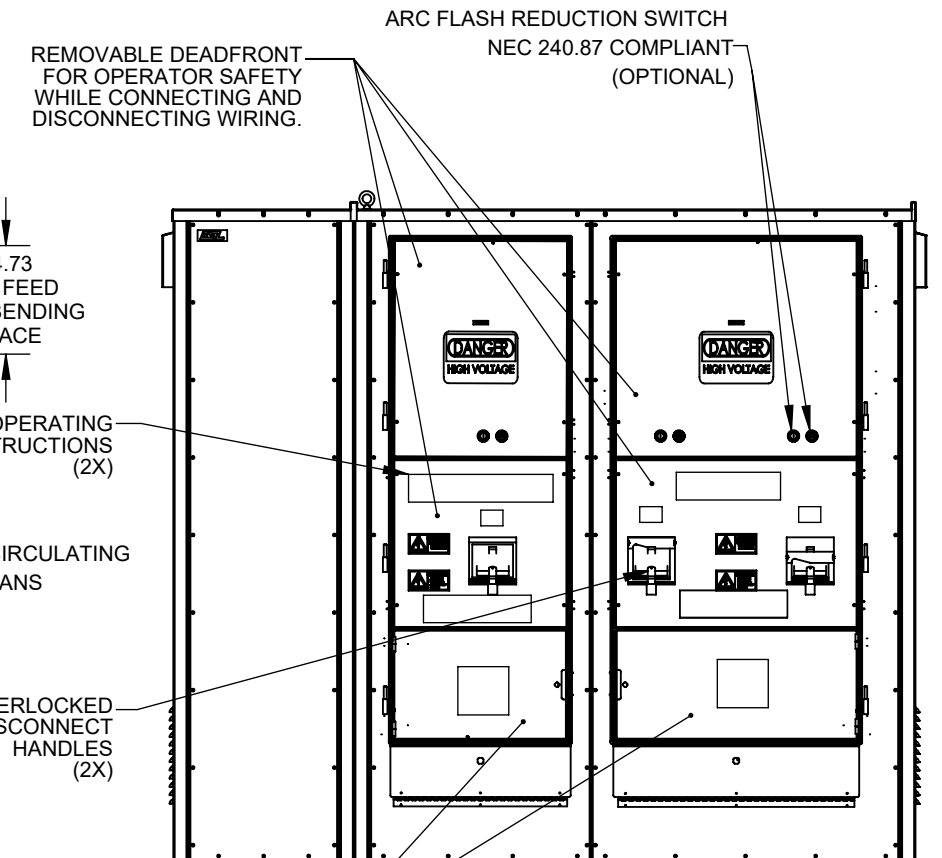

FRONT VIEW
(DOORS REMOVED)

MODEL: 3132-SERIES

0	MAQ	11/30/2021
REV.	BY	DATE

FOR REFERENCE
DESCRIPTION

MATERIAL:	GALV STEEL
THICKNESS:	12 GAUGE
COLOR/FINISH:	WRINKLE GRAY (RAL 7035)
REFERENCE:	1050-31T-ASSY

ESL POWER SYSTEMS, INC.
CORONA, CALIFORNIA
(951) 739-7000 (800) 922-4188
eslpwr.com - info@eslpwr.com

1601-3000A
TRIPLE TRANSFER SWITCH
3 PHASE + N + G

PART NUMBER
3132-SERIES

SHEET
2 OF 2